



BIN-SENSE PLUS

USER MANUAL



INTENTIONALLY BLANK

TABLE OF CONTENTS

INTRODUCTION

Customer Support	2
Manufacturer's Warranty	3
Contact Us	3
Safety	4
Standards.....	4

OVERVIEW

Overview.....	5
Associating Bin-Sense Plus Sites	6
Sensing Cables Overview	7
Bin-Sense Fan Controllers Overview	7
Bin-Sense Remote Unit Overview	7
Fan-Ready Remote Unit Overview	8

BIN-SENSE PLUS SETUP

Bin-Sense Plus Bin Setup.....	9
Fan-Ready Remote Unit Installation.....	9
Plenum Sensor Installation.....	10
Connecting Sensing Cables.....	12
Connecting Sensing Cables without an Extender	12
Connecting Two to Eight Sensing Cables with an Extender	13
Connecting More than Eight Sensing Cables with an Extender.....	14
Ground-Level Component Connection.....	15
Connecting Sensors and Accessories.....	15
Connecting Power (Bins without Extenders).....	16
Connecting Power (Bins with Extenders).....	16

CUSTOMER SUPPORT

For warranty service, please contact your local dealer.

For product support, troubleshooting, or additional questions with your Bin-Sense™ device, please contact your local dealer (www.binsense.com/locate-a-dealer) or Calian Agriculture Ltd. at:



support.agriculture@calian.com



1.833.570.7979



www.binsense.com



MANUFACTURER'S WARRANTY

CALIAN LIMITED TWO-YEAR WARRANTY

Calian Agriculture Ltd. (Calian) warrants that for a period of two (2) years from the date of original purchase, this product will be free from defects in material and workmanship. Calian, at its option, will repair or replace this product or any component of the product found to be defective during this warranty period. Replacement will be made with a new or re-manufactured product or component. No warranty is provided for batteries.

WHAT THIS WARRANTY DOES NOT COVER

This warranty does not cover normal wear of parts or any damage resulting from any of the following: negligent use or misuse of the product; damage in transport, natural disaster, improper installation or use, improper abuse or improper handling. This warranty is limited to only those manufacturing defects that were caused or allowed by Calian.

HOW TO OBTAIN WARRANTY SERVICE

Please contact the local dealer you purchased the product from. For additional support, please contact Calian Agriculture Ltd. at 1.833.570.7979 or visit www.calian.com

CONTACT US

For support questions, troubleshooting, or help with your Bin-Sense device, please contact your local dealer for more information and assistance, or Calian Agriculture Ltd. at support.agriculture@calian.com or 1.833.570.7979.

SAFETY

READ AND FOLLOW ALL INSTRUCTIONS.

SAVE THESE INSTRUCTIONS.

Use the Bin-Sense device for its intended use only, as described in this manual. Do not use attachments not recommended by the manufacturer.

STANDARDS

This manual will use the following standard safety terms and conventions to indicate conditions:

WARNING: INDICATES A HAZARDOUS SITUATION RESULTING IN SERIOUS INJURY OR DEATH.

CAUTION: Indicates a hazardous situation which, if not avoided, could result in moderate injury and/or property damage.

Note: Indicates an important message not related to personal injury or property damage.

INTENTIONALLY BLANK

OVERVIEW

Bin-Sense Plus is a grain monitoring and aeration fan control system that allows for automatically controlled grain conditioning. Users can set fan operation parameters and target outcomes on the Bin-Sense website and Bin-Sense Plus will automatically start and stop aeration fans when ambient conditions are favourable.

Bin-Sense Plus systems use a Bin-Sense Automation Hub to wirelessly connect up to 16 bins to the Bin-Sense servers. The Automation Hub also reads ambient air conditions and makes decisions to turn aeration fans on and off based on ambient conditions and parameters set on the Bin-Sense website.

Each bin in a Bin-Sense Plus system must be equipped with:

- **Temperature and moisture sensing cables** for monitoring grain conditions.
- **Bin-Sense Fan Controllers** to remotely turn aeration fans on and off.
- **A Bin-Sense plenum sensor** for measuring air conditions in the bin plenum.
- **A Bin-Sense Remote unit** to connect all accessories on the bin and communicate with the Automation Hub.

Some large bins may require more than one Remote unit to read the large number of sensing cables required to accurately monitor grain conditions.

Bin-Sense Fan-Ready Remote units are recommended for Bin-Sense Plus systems as they are optimized connecting to Bin-Sense Plus accessories.

ASSOCIATING BIN-SENSE PLUS SITES

For the Automation Hub to communicate with Remote units, the site must be associated by a Bin-Sense dealer on the Bin-Sense website. The association process involves entering the serial numbers of the Automation Hub and Remote units and assigning those serial numbers to specific bins in the Bin-Sense software so that the system knows what Bin-Sense units are installed on each bin.

Once associations are complete, the Bin-Sense server will send the Automation Hub information about which Remote units to communicate with. After this, as long as the Automation Hub and all Remote units are powered on, Bin-Sense Plus will begin reporting grain conditions to the Bin-Sense app and website, and automatic grain conditioning can be enabled and configured from the Bin-Sense website.

Before going to the site to install Bin-Sense Plus, it is recommended to perform associations and select Remote units for each bin. The Bin-Sense website offers a printed site map that shows each bin and lists the serial number of the Remote unit assigned to that bin to easily assign items on site. Performing associations in advance will also allow units to begin communicating as soon as they are powered on.

SENSING CABLES OVERVIEW

Bin-Sense sensing cables hang from the roof of a grain bin and sense the temperature, or temperature and moisture of grain in the bin. Cables are arranged along concentric circles throughout the bin to ensure all grain is effectively monitored.

Bin-Sense cables are available in two different styles: angle mount, and hanger mount. Angle mount cables are installed outside the bin roof and run through a hole in the roof. Angle mount cables usually require additional support brackets to distribute the weight and force of grain on the cable throughout the roof structure. Hanger mount cables are designed to be hung from the truss structure found in the roof of larger bins. More details and installation instructions for sensing cables are available at binsense.com/support.

Bin-Sense systems are compatible with many other company's sensing cables. Many bins with sensing cables already installed can be switched to Bin-Sense systems if the existing cables are digital sensing cables with two-pin, all-weather Tyco connectors.

BIN-SENSE FAN CONTROLLERS OVERVIEW

Bin-Sense Fan Controllers are an accessory device for Bin-Sense Live and Plus systems that allow Bin-Sense to remotely control grain bin aeration fans. Bin-Sense Fan Controllers serve as an interface between the high voltage wiring of aeration fans and the low voltage signal wiring of a Bin-Sense system.

Bin-Sense Fan Controllers are compatible with Bin-Sense Live Master and Remote units, Bin-Sense Plus Remote units, and can also be tested with Bin-Sense Direct units.

Two different versions of Bin-Sense Fan Controllers (240V and 600V) are available depending on the voltage of the aeration fan electrical system. More details and installation instructions for Fan Controllers are available at binsense.com/support.

BIN-SENSE REMOTE UNIT OVERVIEW

Remote units serve as peripheral devices in a Bin-Sense Plus system. At least one Remote unit must be installed on each bin in a Bin-Sense Plus system. The Remote units read sensing cables and plenum sensors, communicate with Fan Controllers, and communicate wirelessly with the Automation Hub.

Bin-Sense Fan-Ready Remote units are recommended for Bin-Sense Plus systems. Fan-Ready Remote units differ from standard Remote units in that Fan-Ready Remotes have a dedicated sensor link cable for communicating with Fan Controllers and plenum sensors in addition to a sensor link cable for communicating with sensing cables.

This manual describes how to install and connect a Remote unit as part of a Bin-Sense Plus system. More details on Remote unit setup and operation can be found at binsense.com/support.

FAN-READY REMOTE UNIT OVERVIEW

- A. LID LATCH CLIPS
- B. MAGNETIC FEET
- C. POWER CONNECTION (SOLAR PANEL FOR BATTERY POWERED APPLICATIONS)
- D. FAN CONTROL LINK CABLE (FOR FAN CONTROLLERS AND PLENUM SENSORS)
- E. SENSOR LINK CABLE (FOR SENSING CABLES)

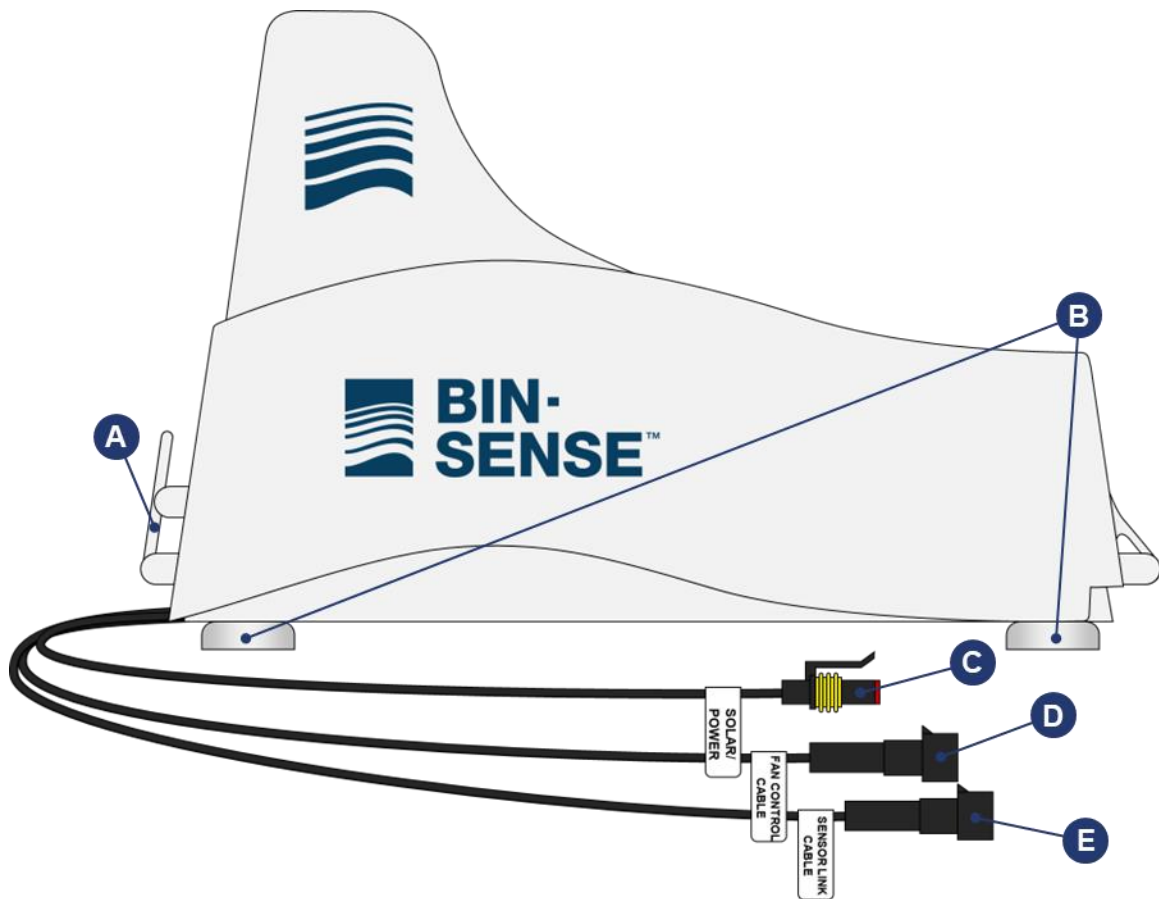

Figure 1: Fan-Ready Remote unit overview.

BIN-SENSE PLUS BIN SETUP

FAN-READY REMOTE UNIT INSTALLATION

1. Select a location on the side of the bin for the Fan-Ready Remote unit:
 - For Bin-Sense Plus systems, it is recommended to install Remote units near ground level. Select a location on a few feet up the side of the bin where the Remote unit will not be in the way of any other equipment and is not likely to be tampered with.
 - Choose a location where the Remote unit has line-of-site to the Automation Hub antenna.
 - If possible, locate the Remote unit near Fan Controllers to minimize the length of link cable required to connect Fan Controllers.
2. Use the magnetic feet to mount the Remote unit on the side of the bin with the antenna fin end closest to the ground.
3. Refer to the remainder of this manual for instructions on how to connect the Remote unit to the rest of the Bin-Sense accessories.

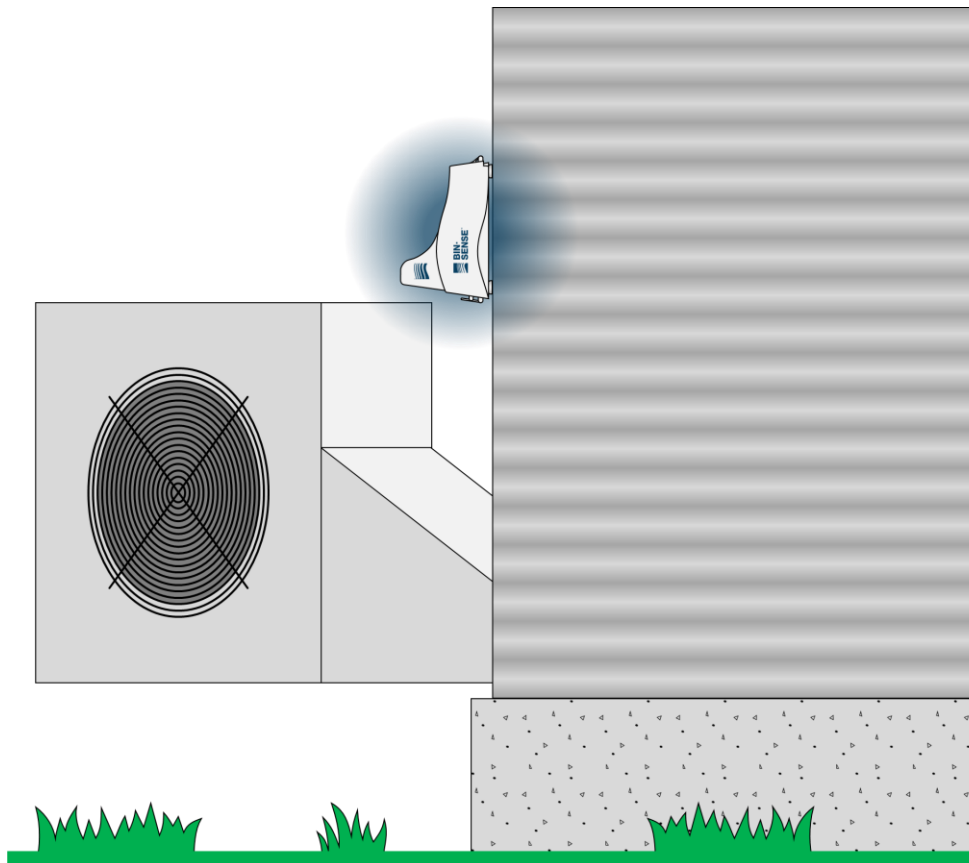

Figure 2: Example suggested location for a Fan-Ready Remote unit.

SETTING THE REMOTE UNIT RADIO CHANNEL

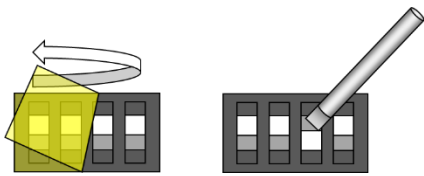

Figure 5: DIP Switches

Bin-Sense Remote units wirelessly connect to the Automation Hub using a radio system similar to Wi-Fi. In order to connect to the Automation Hub, Remote units must be associated through the Bin-Sense website and must be on the same radio channel.

The radio channel is set using the radio channel DIP switches. Channels 12 through 23 are available with the default channel being 23. The radio channel only needs to be changed if there are other Bin-Sense Live or Bin-Sense Plus systems installed nearby (within roughly 2 km or 1.5 miles).

To set the radio channel, use a small flat screwdriver to change the individual switches to match the pattern of the desired channel as shown below. The transparent yellow film covering the switches can be removed with tweezers or can be pushed through with the screwdriver.

12	13	14	15	16	17
↓ 1 ↓ 2 ↓ 3 ↓ 4	↓ 1 ↓ 2 ↓ 3 ↓ 4	↓ 1 ↓ 2 ↑ 3 ↓ 4	↓ 1 ↓ 2 ↑ 3 ↑ 4	↑ 1 ↓ 2 ↓ 3 ↓ 4	↑ 1 ↓ 2 ↓ 3 ↑ 4
18	19	20	21	22	23
↑ 1 ↓ 2 ↑ 3 ↓ 4	↑ 1 ↓ 2 ↑ 3 ↑ 4	↑ 1 ↑ 2 ↓ 3 ↓ 4	↑ 1 ↑ 2 ↓ 3 ↑ 4	↑ 1 ↑ 2 ↑ 3 ↓ 4	↑ 1 ↑ 2 ↑ 3 ↑ 4

Figure 6: DIP Switch Settings

PLENUM SENSOR INSTALLATION

The plenum sensor measures the air temperature and relative humidity in the airspace under the bin floor. The plenum sensor is mounted on the outside of the bin and passes through a hole in the bin wall.

TOOLS REQUIRED

- Drill
- 1" hole saw
- 3/8" socket bit

INSTALLATION INSTRUCTIONS

1. Select and mark a location on the outside of the bin to install the plenum sensor:
 - The plenum sensor should be at least 10 feet away from the nearest aeration fan.
 - The plenum sensor should be installed so that its height is halfway between the concrete foundation and the perforated steel floor.
 - Select a concave location on the bin wall where the corrugation is deepest.
2. Use the 1" hole saw to make a hole in the bin wall at the marked location.
3. Position the plenum sensor through the hole with metal sensor tip inside the bin plenum and the green plastic sensor pointed towards the bin floor.
4. Use the two 1 ½" self-tapping screws to secure the plenum sensor in place. Ensure the gasket is compressed and making consistent contact with the bin wall.
5. Run the link cable downward and away from the plenum sensor, and towards the location of the Remote unit. Secure the link cable in place with the included link cables.

NOTE: Ensure the plenum sensor is installed with the green plastic portion of the sensor pointed down towards the concrete foundation.

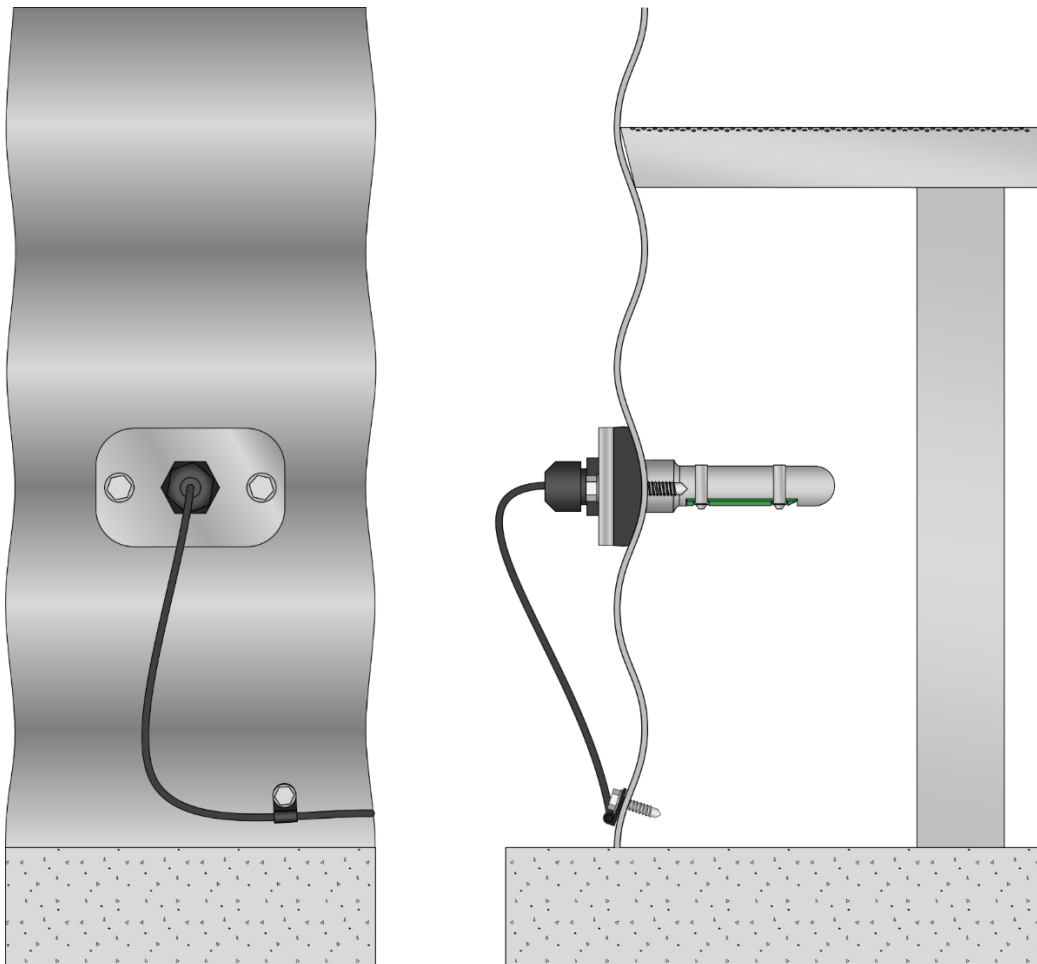

Figure 3: Plenum Sensor installation.

CONNECTING SENSING CABLES

Once sensing cables installed and supported with the appropriate roof brackets, they must be connected together to the Remote unit at the bottom of the bin.

On small and medium sized bins with only a few sensing cables, all the cables can be directly connected together with the Remote unit using a terminal box or splitter. Larger bins with more than a few cables require a Bin-Sense Extender to connect cables together into smaller groupings. The Bin-Sense quote tool will advise when a bin requires an Extender.

CONNECTING SENSING CABLES WITHOUT AN EXTENDER

1. Use a Bin-Sense Direct unit to ensure each sensing cable has a unique cable ID.
2. Connect each sensing cable to a link cable and run all the link cables to a central location on the roof of the bin.
3. Use a splitter or terminal box to connect the link cables from each sensing cable.
 - When using a splitter, use link cables with male and female connectors. Coil and secure any unused link cable length.
 - When using a terminal box, use link cables with only a female end and unterminated wire on the other end. Cut link cables to the proper length before terminating in the terminal box.
4. Run a single link cable from the terminal box or splitter at the top of the bin to the Remote unit at the bottom of the bin.
 - Secure the link cable in place using the included p-clips.
 - Ensure there is slack in the link cable so that it is not pulled tight or sharply bent over the roof eave.
5. Connect the link cable at ground level to the “SENSOR LINK CABLE” connection of the Remote unit.

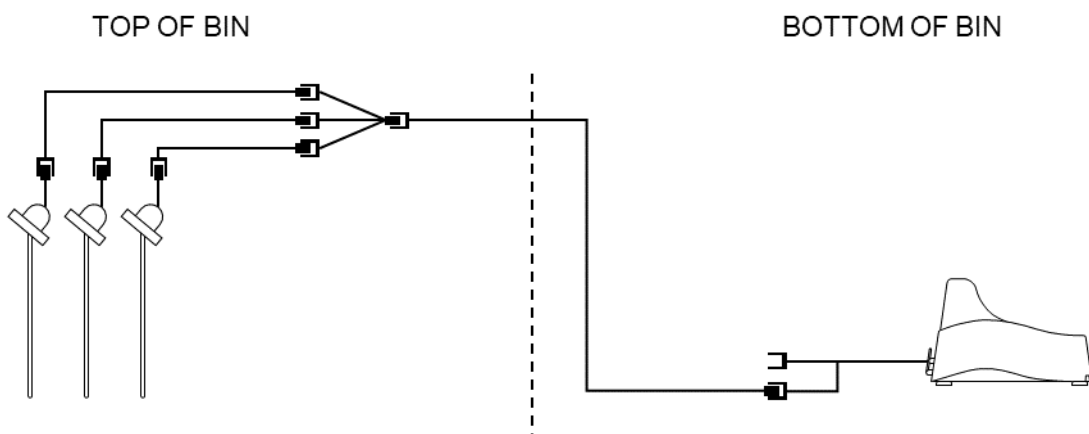

Figure 4: Sensing cables connected without an extender.

CONNECTING TWO TO EIGHT SENSING CABLES WITH AN EXTENDER

1. Use a Bin-Sense Direct unit to ensure each sensing cable has a unique cable ID.
2. Connect each sensing cable to a link cable and run all the link cables to a central location on the roof of the bin.
3. Connect each link cable to one of the extender input (female) connectors.
4. Run two link cables from the extender at the top of the bin to the Remote unit at the bottom of the bin.
 - The male and female connectors of the two cables should be arranged in opposite positions. I.e., at the roof of the bin, one link cable should have a female and, and the other cable should have a male end.
 - Secure the link cables in place using the included p-clips.
 - Ensure there is slack in the link cables so that they are not pulled tight or sharply bent over the roof eave.
5. Connect the link cable with the male end to the power connection of the Extender.
6. Connect the link cable with the female end to the sensor connection of the Extender.
7. At ground level, connect the link cable with the male end to the “SENSOR LINK CABLE” connection of the Remote unit.
8. At ground level, connect the link cable with the female end to the power output connection of a Fan Controller. A splitter or terminal box may be required to distribute the power output of the Fan Controller to all components requiring power.

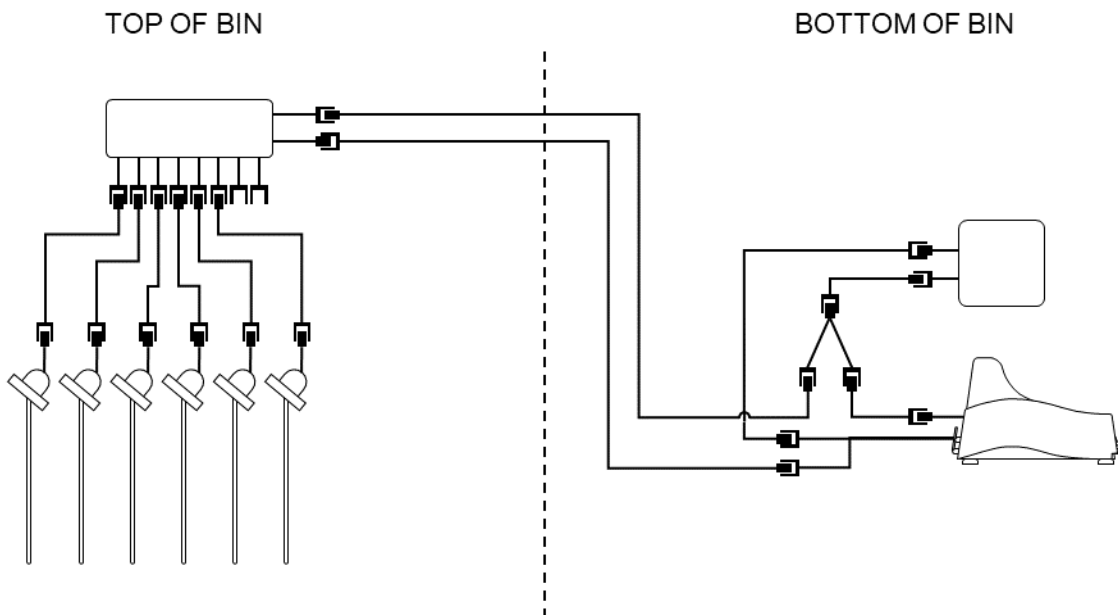

Figure 5: Sensing cables connected with an Extender.

CONNECTING MORE THAN EIGHT SENSING CABLES WITH AN EXTENDER

1. Use a Bin-Sense Direct unit to ensure each sensing cable has a unique cable ID.
2. Plan out the cable connection arrangement before beginning.
 - Bin-Sense Extenders have eight inputs. On bins with more than eight sensing cables, some cables need to be grouped together to share an Extender input.
 - When grouping cables together, the cables must not exceed the maximum capacitance limits specified by the Bin-Sense quote tool.
 - Create a map of the cables on the bin roof and how they will be grouped and connected to the Extender.
3. For sensing cables sharing an extender input, connect each cable to a link cable and run all the link cables to location on the bin roof that is central to the cables in that grouping.
4. Connect each link cable from step three to a terminal box or splitter.
5. Repeat steps three and four for each group of sensing cables sharing an Extender input.
6. Connect the remaining cables (that are not sharing an extender input) as well as the outputs of all the splitters or terminal boxes to the extender input connectors.
7. Run two link cables from the extender at the top of the bin to the Remote unit at the bottom of the bin.
 - The male and female connectors of the two cables should be arranged in opposite positions. I.e., at the roof of the bin, one link cable should have a female and, and the other cable should have a male end.
 - Secure the link cables in place using the included p-clips.
 - Ensure there is slack in the link cables so that they are not pulled tight or sharply bent over the roof eave.
8. Connect the link cable with the male end to the power connection of the Extender.
9. Connect the link cable with the female end to the sensor connection of the Extender.
10. At ground level, connect the link cable with the male end to the “SENSOR LINK CABLE” connection of the Remote unit.
11. At ground level, connect the link cable with the female end to the power output connection of a Fan Controller. A splitter or terminal box may be required to distribute the power output of the Fan Controller to all components requiring power.

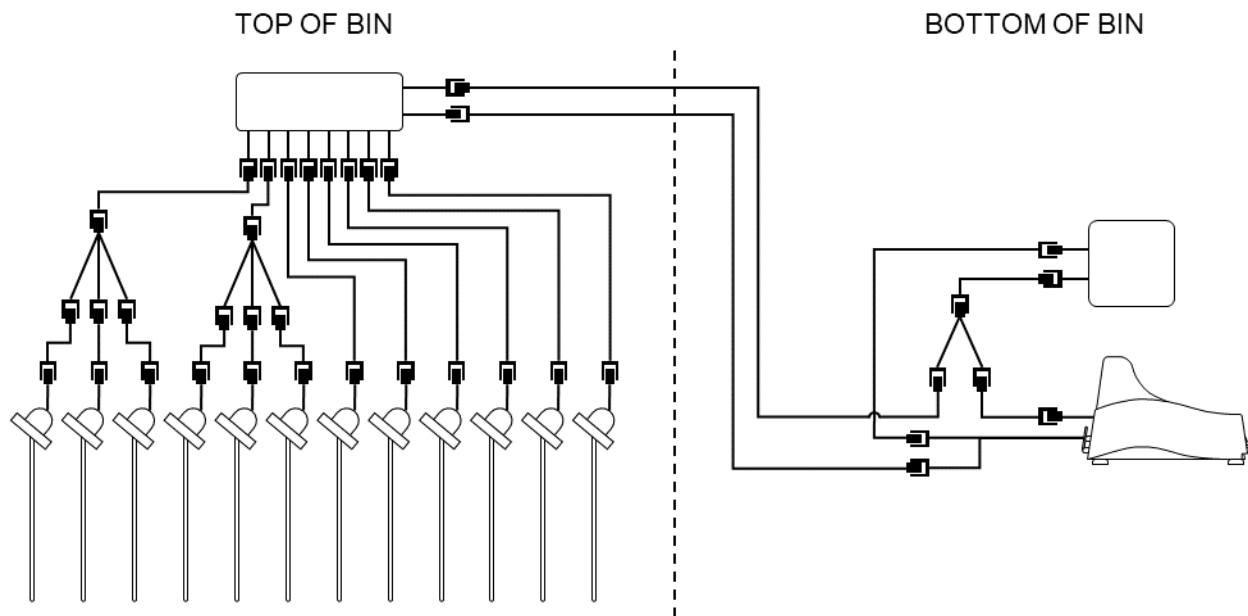

Figure 6: More than eight sensing cables connected with an Extender.

GROUND-LEVEL COMPONENT CONNECTION

Bin-Sense Fan-Ready Remote units have two female connectors: one for connecting sensing cables, and the other for connecting Fan Controllers and Plenum Sensors at ground level. Fan Controllers are susceptible to interference caused by long link cable lengths; the dedicated connector allows isolation from sensing cables which often require long link cables.

Bin-Sense Remote units are powered by the power output of Bin-Sense Fan Controllers. Fan Controllers must be connected to power at all times in order to provide consistent power to Bin-Sense Remote units. Aeration fans do not need to be running to provide power to Remote units.

CONNECTING SENSORS AND ACCESSORIES

1. Connect the link cable from the top of the bin (that is connected to all the sensing cables on the bin) to the "Sensor Link Cable" connection of the Remote unit.
2. Use a splitter or terminal box to connect the "Fan Control Cable" connection of all Fan Controllers on the bin.
3. Connect the Plenum Sensor to the splitter or terminal box from step two.
4. Connect the output of the splitter or terminal box from step two to the "Fan Control Cable" connection of the Remote unit.

CONNECTING POWER (BINS WITHOUT EXTENDERS)

1. Use a link cable to connect the “Power Cable” connection from the Remote to the “Fan Power Cable” from a Fan Controller.

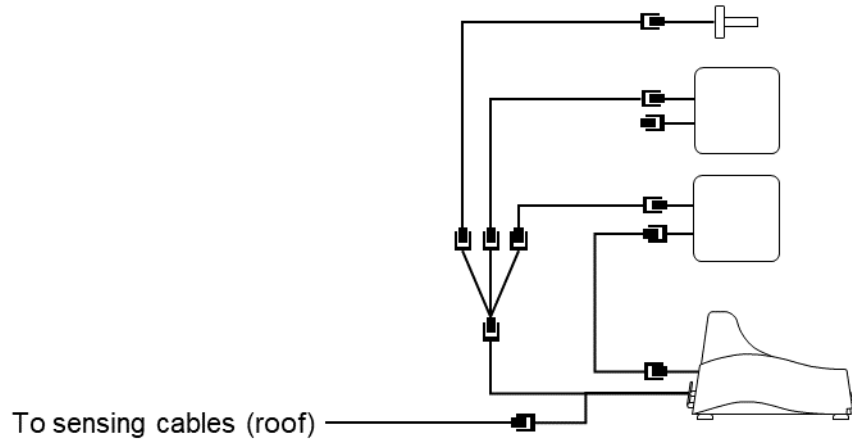

CONNECTING POWER (BINS WITH EXTENDERS)

2. For bins with an Extender, connect a splitter or terminal box to the “Fan Power Cable” connection of one Fan Controller. **Do not connect the “Fan Power Cable” connections from more than one Fan Controller together.**
3. Connect the link cable connected to the Extender power cable to the splitter from step one.
4. Connect the “Power Cable” connection from the Remote to the splitter from step one.

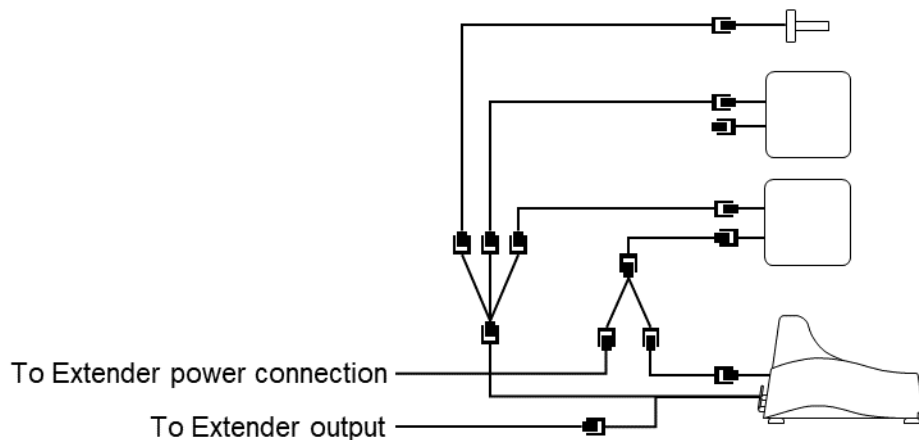

INTENTIONALLY BLANK

Manufactured in Canada by



Head Office:
Calian Agriculture Ltd.
118 Husum Road
RM of Sherwood, SK CANADA
S4K 0A4

support.agriculture@calian.com

1-833-570-7979

www.binsense.com